

Installation, Operation, Maintenance Instructions

HiFlo Positioner

CAUTION :

1. Use pressure relief valves for high pressure piping.
2. Use explosion proof valves/accessories for dangerous media piping.
3. Use fire safe valves for piping where chances of fire by external means.
4. Use seismic proof valves where chances of earthquake are frequent.
5. Check whether location of the valve mounting is of the same service/application as specified on the marking plate.

 **MASCOT**

Our reputation

GENERAL INFORMATION

The manual for Mascot HiFlo Positioner mounted on control valves offers complete instructions for installation, calibration, troubleshooting, and doing maintenance as needed.

The manual should be read thoroughly by product users and maintenance personnel and the instructions contained in this manual should be followed exactly prior to operation of the positioner. For any queries and clarifications on this manual, just give a call to the Mascot representative.

Adhering to the guidelines strictly will avoid possible injury to personnel or damage to equipment. Any modification in this product, or using non-factory or inferior parts, employing maintenance procedures other than prescribed can affect performance adversely, moreover, it can be dangerous to personnel and equipment, and also void existing warranties.

NOTE : The Numbers mentioned in parenthesis correspond to item numbers in Figures 7.

HiFlo Positioner Overview

Mascot HiFlo Positioner offers you a choice of either pneumatic module for air control signals or can be mounted with an electro-pneumatic (I/P) module for milli-ampere electrical control signals. While being double-acting, it has the capability to supply air to either sides of the actuator piston while other side for exhausting to the atmosphere. Being quite dynamic, the unit adjusts to two and three-way split range and no special feedback springs are needed. Without modification to the actuator, the HiFlo Positioner can be mounted on either Mascot linear or rotary actuators.

A supply regulator is usually not required as the positioner is insensitive to supply pressure changes and can handle supply pressures from 30 to 150 psi; however, an air filter is highly recommended.

NOTE : ISA Standard S7.3 air supply is a must. (a dew point at least 18°F below ambient temperature, particle size below 5 microns, oil content not to exceed 1 part per million).

Positioner Operation

HiFlo Positioner is force-balanced equipment. A typical HiFlo Positioner is as appearing in the Figure 1, installed on a double-acting actuator for air-to-open action. A balance of two forces dictates positioning; one proportional to the stem position and the other to the instrument signal.

The current signal is first converted to a 3-15 psi air signal, with the I/P converter. In case of the pneumatic model, the 3-15 psi signal goes into the positioner. A downward force is created as the pressure signal acts upon the diaphragms in the instrument signal capsule. The top end of the feedback spring through the follower arm and cams gets the motion of the actuator stem. This results in tension in the feedback spring varying with the change in the stem position.

The system will be in equilibrium and the stem will be in the position called for by the instrument signal when these opposing forces balance exactly.

The balance beam will move up (or down) and, by means of the spool valve, will change the output pressures and flow rate in case these opposing forces are not in balance. The piston will thus continue to move till the tension on the feedback spring becomes equal to the pressure of instrument signal.

Positioner operations are presented in a detailed sequence as below :

The downward forcing of the instrument signal capsule and balance beam occurs due to increase in the instrument signal forces.

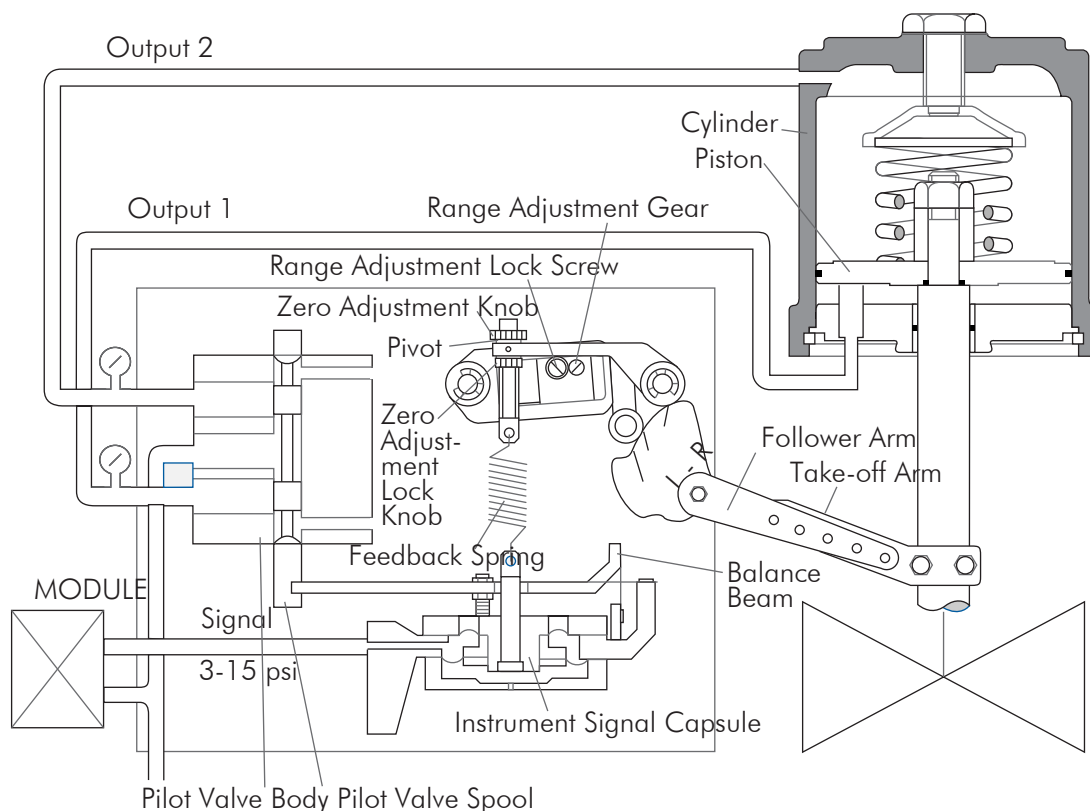

Figure 1 : Schematic for Air-to-Open (Retract) Positioner

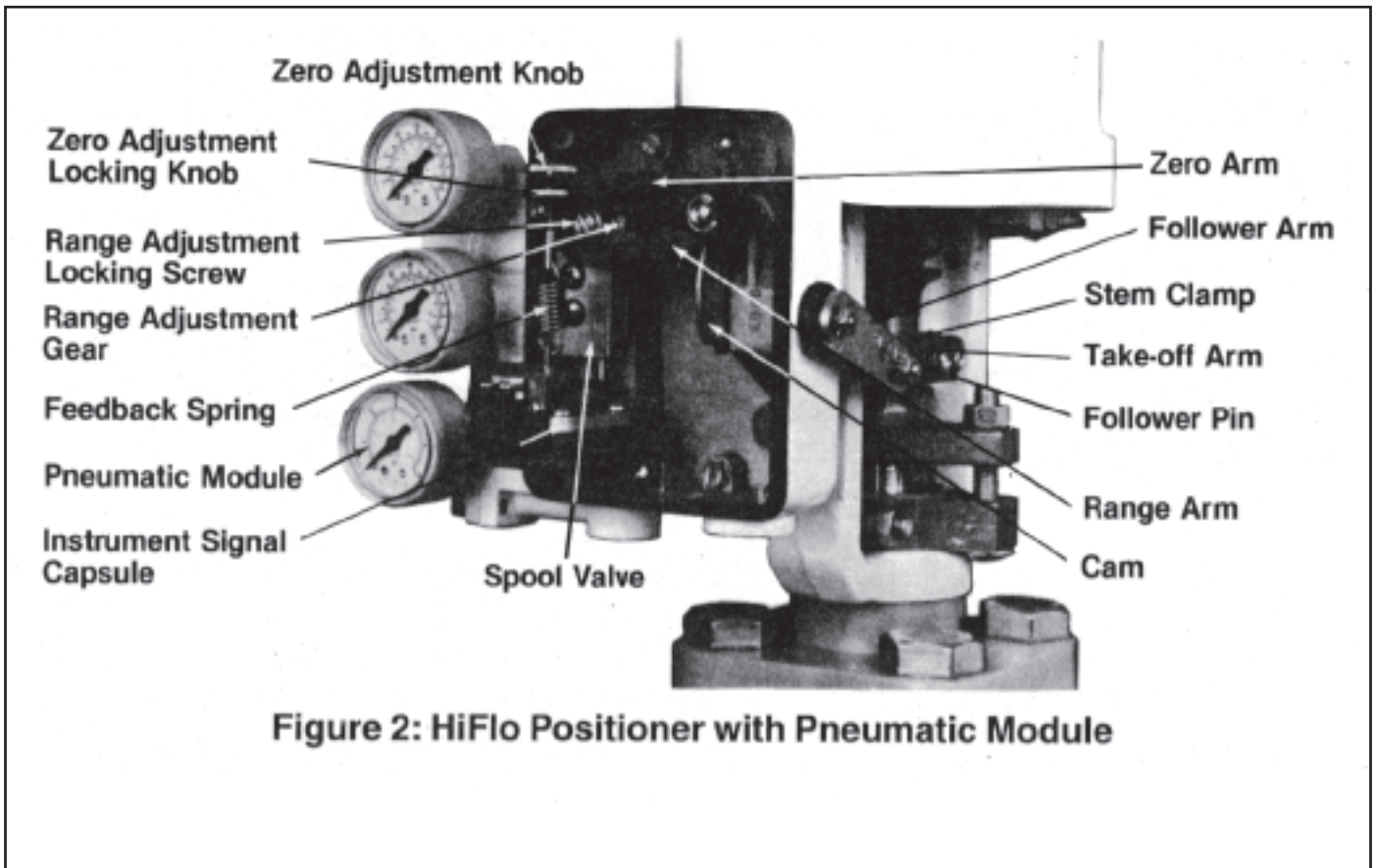

Figure 2: HiFlo Positioner with Pneumatic Module

The downward motion of the balance beam leads to pulling of the pilot valve spool downward. The pilot valve ports open, and air is supplied to port 1 and exhausting air from port 2. The upward movement of the actuator piston occurs.

The transmission of this upward motion of the piston to the positioner occurs through the feedback linkage and cam. This results in the being stretching of the spring proportionally to the position of the valve. Till the force in the feedback spring increases sufficiently to counter the force generated by the instrument signal capsule, the piston continues to stroke upward. It is at this point that the equilibrium position begins to reach in the balance beam spool. The air flow rate to the actuator is reduced as the valve spool ports begin to close.

On the piston reaching the desired position, the tension force in the feedback spring will balance the force created in the instrument signal capsule.

Unless a change in the instrument signal occurs, the balance beam and instrument signal capsule remain in their equilibrium positions and no air is flowing to the actuator. A reversal of the described actions occurs with a decrease in the instrument signal. An equivalent downward movement in the actuator piston and stem occurs.

Installation

The details on doing installation of the positioner on linear and rotary actuators and reversing the air action on linear and rotary actuators is covered in the installation section of this manual.

Installing Positioner on Linear Actuators

How to install or retrofit the HiFlo Positioner on varying sizes of linear actuators is detailed below :

NOTE : Remove the existing positioner, bracket, stem clamp, and associated bolting when retrofitting the HiFlo Positioner to an actuator equipped with a Moore or comparable positioner. In case of retrofitting to an actuator that has a Mascot HiFlo pneumatic positioner, the same bracket, stem clamp, and bolting can be used very comfortably.

1. Figures 2 illustrates on how to place the new stem clamp (if applicable) onto the actuator stem with the boss on the right side.
2. Figure 3 shows how to mount the positioner bracket to the yoke leg which has the stroke indicator plate attached to it and in the correct position.
3. Bolt the take-off arm to the stem clamp so that the arm curves upward (toward the cylinder) - if it is not welded to the stem clamp. The holes and slots should line up in the follower arm and the take-off arm respectively. Figures 2 should be referred to.
4. Figure 4 - For the proper air action, install the cam, cam shaft and follower arm. In case of an air-to-open action, the cam needs to be installed with the letters L-R facing toward the cam shaft.
The return spring needs to be fed into hole "A."
In case of air-to-close action, the L-D side of the cam must face toward the cam shaft and the return spring should be fed into hole "B."
5. On the outside of the cam shaft, the rubber boot should be inserted. With the hole markings facing outward, feed the appropriate stroke follower arm onto the cam shaft boss. With the lock washer and nut, fasten securely.

- Positioner is to be mounted on the bracket. With the follower pin, the follower arm and take-off arm should be connected in a way that allows the follower arm to move freely.

CAUTION : To prevent premature wear, ensure the lubrication of the follower pin and take-off arm, where contact is made. We recommend light industrial grease for lubrication. Improper or no lubrication may lead to premature wear, leading to failure of equipment. Personal injury also is likely.

- In case of air-to-open (air-to-retract) air action, connect tube "out-put 1" to the bottom and "output 2" to cylinder top. In case of air-to-close (air-to-extend) action, tube "output 2" to the bottom and "output 1" to the cylinder top.
- 1/4" NPT tubing connections are to be used to attach air supply and instrument tubing.

CAUTION : The recommended instrument signal on the pneumatic module is 3-15 psi. Air pressure higher than the prescribed is likely to damage the module. 30 psi is the limit of the module.

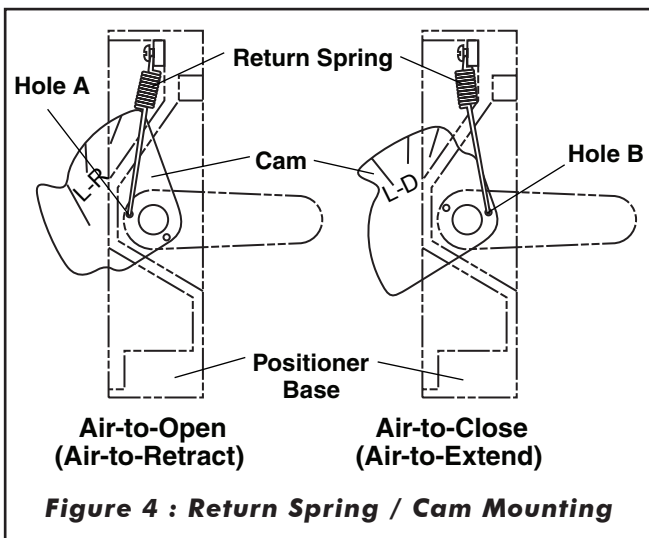
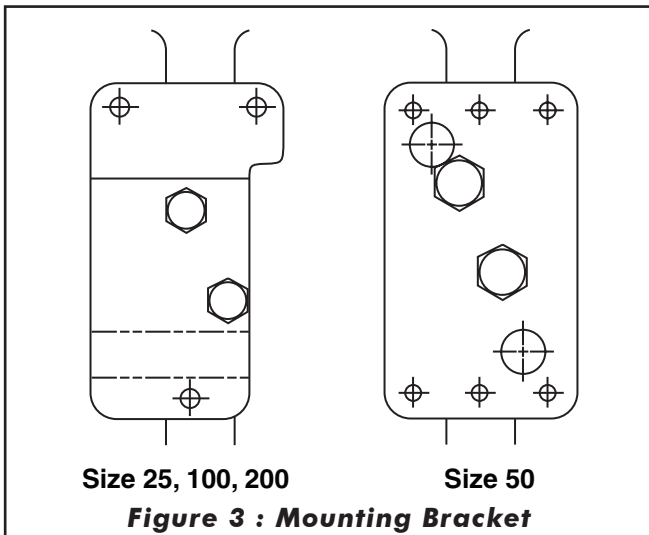

Reversing Air Action on Linear Actuators

No additional parts are required for reversing the air-action of the positioner. The tubing will need to be rerouted on the linear actuator.

For reversing the air-action on all sizes of linear actuators, follow the guidelines below:

- For reversing the air-action of the actuator, refer Installation, Operation, Maintenance Instructions 2.
- After disengaging the return spring from the cam, remove the cam from the cam shaft.
- The steps 4-8 in the "Installing Positioner on Linear Actuators" section of this bulletin are to be followed to reverse the cam, return spring, and tubing for the desired air-action.

Installing Positioner on Rotary Actuators

When installing the HiFlo positioner on all sizes of rotary actuators, proceed as follows - in case the cam and follower arm are not already installed. otherwise step 7 can be directly referred to.

- The feedback spring should be removed and the zero adjustment arm must be rotated out of the way. From the range adjustment arm post, remove the snap ring and then the range adjustment arm is to be removed.
- Refer Table 1 - With the desired cam and its identification letter facing towards the cam shaft, the cam (56) should be made to slide onto the end of the cam shaft having the shorter shoulder (57). The star lock washer (26) and nut (25) should be used for fastening.
- With part identification number facing out, insert the follower arm (58) into the back recess of the positioner. Through the inner bearing, slide the cam shaft. Then, over the longer stepped shoulder of the cam shaft, slip the flatted hole of the follower arm.
- To the threaded portion of the cam shaft nut (59), place small amount of threadlocking compound (Loctite #222 or equivalent). Through the outer bearing, slide the cam shaft nut (59) and screw it onto the cam shaft (57). Ensure tightening the cam shaft together firmly for secure clamping of the follower arm (58). Make sure the cam (56) is tightly secured to the cam shaft. No slippage should be allowed. A small amount of grease is to be applied to the bent end of the return spring (18) and through the hole in the cam, feed it. Over the screw, loop the other end of the return spring (19). Screw the return spring into the positioner base.

NOTE : Screw head will not bottom out.

- The range adjustment arm (13) and its snap ring (8) should be replaced.
- Rotating the zero adjustment arm (22) back into place, reinstall the feedback spring (34).
- The follower pin should be insert into the hole in the actuator lever arm and driven firmly into place. A hammer can be used for this purpose (Refer Figure 5).
- Grease should be applied to the sliding surfaces of the follower arm (58) prior to mounting the positioner to the transfer case. Ensure to guide the follower arm when mounting the positioner to the transfer case, so that the pin slides in the slot on the follower arm (Refer Figure 5). With the three mounting screws, fasten the positioner to the transfer case. To verify that the pin is riding in the follower arm slot, push up on the cam or remove the transfer case cover plate to inspect.

Table 1: Rotary Actuator Cam Characteristic Chart

Cam No. □ □ □	Fail □ Action □	Characteristic ⁽¹⁾	
		Equal Percent □	Linear
□ 46467 □	Air to Open □ Air to Close □	B □	C
□ □		C □	B

Markings are in the form of letters which are on either side of the cam - in stamped form.

CAUTION : Since the coverplate houses a shaft support bearing, failure to replace the coverplate before operating the actuator will damage the shaft.

Reversing Air-Action on Rotary Actuators

By mounting the yoke to the opposite side of the transfer case, reversing the action on rotary actuators is achieved. The manual is to be referred to for Installation, Operation, Maintenance Instructions 10, DiskFlo Control Valves; Installation, Operation, Maintenance Instructions 9, VFlo Control Valves for details; or Installation, Operation, Maintenance Instructions 11, Rotary Actuators.

Calibration

Calibration of both rotary and linear actuators can be done by same procedures. As such, Mascot positioners mounted on valves are calibrated at the factory; but due to possibility of changes because of shipping and handling, it is advisable that before operating the valve, the calibration should be checked. Depending on the valve stroke and split range required, three feedback springs are available for use in the HiFlo Positioner. The standard silver spring is used with standard stroke actuators and provides 1, 2, or 3-way split ranges (3-15, 3-9, 9-15, 3-7, 7-11, or 11-15 psi with the pneumatic module, or ranges of 4-20, 4-12, 12-20, 4-9.3, 9.3-14.6, 14.6-20 mA with the I/P module). With short stroke actuators, a red spring is used (1/2 - inch on 25 or 50 square-inch actuators, 3/4 and 1-inch strokes on 100 square-inch actuators) and provides 1, 2, or 3-way split ranges. For a 4-way split range on standard stroke actuators, a green spring is used.

WARNING : Be sure to keep hands, hair, and clothing away from moving parts. Failure to do so can cause serious personal injury - especially when stroking the actuator during calibration.

Calibrating Positioner Zero and Span

Please refer to Figure 2 for Calibration. Proceed as follows :

1. In case of standard ranges (3-15 psi, 4-20 mA), the zero adjustment locking knob is to be loosened and adjusted until the valve begins to stroke at just over the de-sired zero point (usually 3 psi pneumatic, 4 mA electrical).
2. About 1 /8 turn loosening range adjustment should be done in locking screw.
3. Turn the range adjusting gear with a screwdriver so that the valve is at full stroke at just under the desired maximum range point (usually 15 psi pneumatic, 20 mA electrical).
4. Check the zero while returning to minimum signal (usually 3 psi pneumatic, 4 mA electrical). Repeat steps 1 - 4 if necessary.
5. The range adjustment locking knob must be tightened.
6. The zero adjustment locking knob must be tightened.

MAINTENANCE

HiFlo Positioner Maintenance

For the HiFlo positioner on both rotary and linear actuators, the general maintenance procedures are the same. Check positioner for proper operation by following the maintenance steps outlined below. This should be done at least once every six months.

1. A clean air supply, free of dust, oil, and water needs to be maintained. Use of an air filter to ensure a clean air supply to the positioner is recommended. The air filter should be checked and maintained at least every six months.

NOTE : It is necessary that the air supply conforms to ISA Standard S7.3 (a dew point at least 18°F below ambient temperature, particle size below 5 microns, oil content not to exceed 1 part per million).

2. Free movement for all arms and levers should be ensured.
3. Tighten any loose parts.
4. There should be no leaks in the air supply.
5. Managing problems will be easy with the "Troubleshooting" section of this manual.

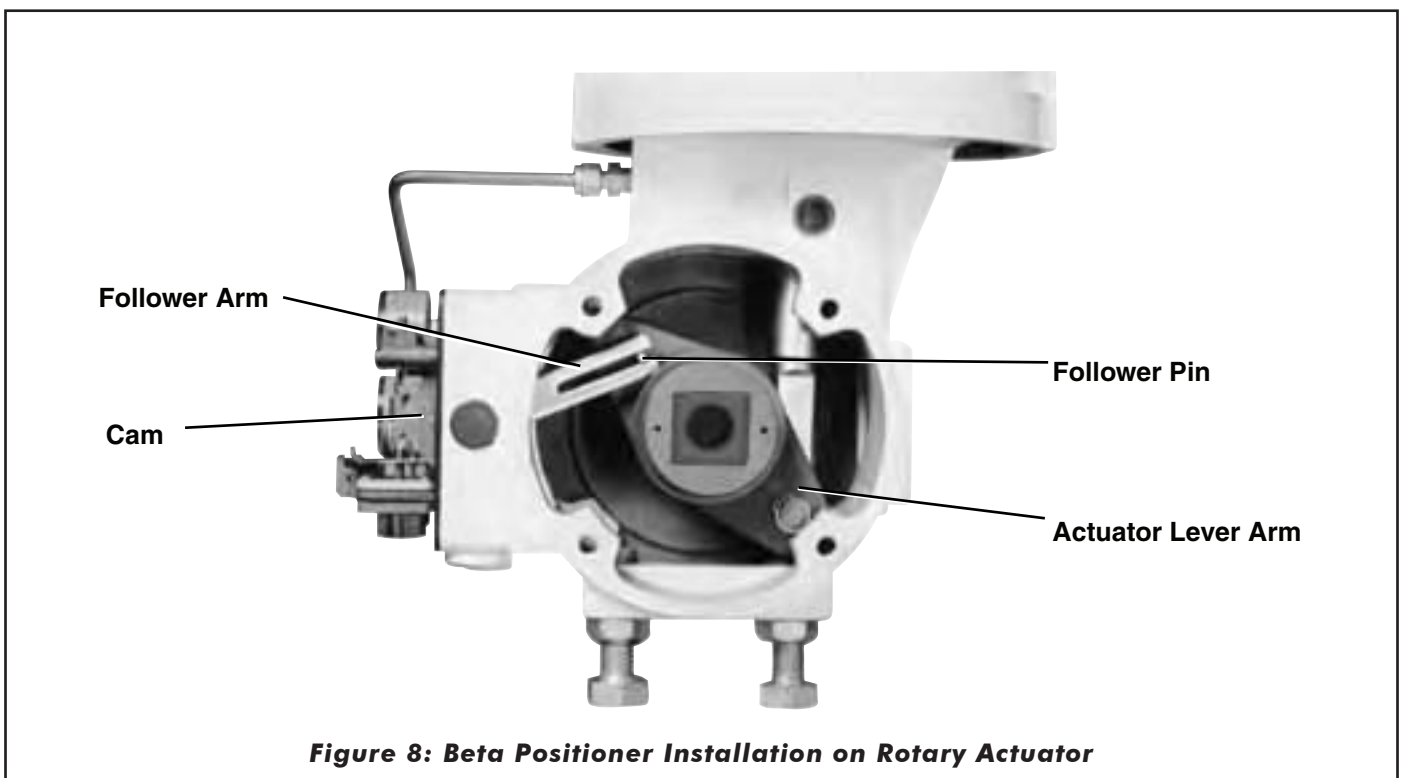

Figure 8: Beta Positioner Installation on Rotary Actuator

Removal and Repair of Pilot Valve

Please refer to Figure 2 or 5 to remove or repair the positioner pilot valve. The procedure to be followed is given below.

The zero adjustment locking knob (23) and zero adjusting knob (20) should be loosened. The feedback spring (34) and the zero screw (24) should be disconnected. The feedback spring should be removed from the positioner assembly. The zero arm (22) is to be rotated out of the prior to removing the snap ring (8) holding the range adjustment arm (13) to the base assembly (7). The range adjustment arm to be removed.

The two screws (53) holding the pilot valve to the base need to be removed. Separate the pilot valve from the positioner (be care-ful not to cause damage to the pilot valve or balance beam). From the spool valve body (52), slide the pilot valve (40). Check it for dirt build-up or sticking. The spool should slide freely and fall through by its own weight when held vertically - for a smooth operation. A degreasing solvent should be used to clean both the pilot valve spool and body. After it is clean, insert the spool back into the body. To check that it slides freely, move back and forth. This will ensure proper operation. Reclean or replace if spool doesn't slide freely.

CAUTION : Do not apply oil or grease to the spool. It will adversely affect the performance of the positioner

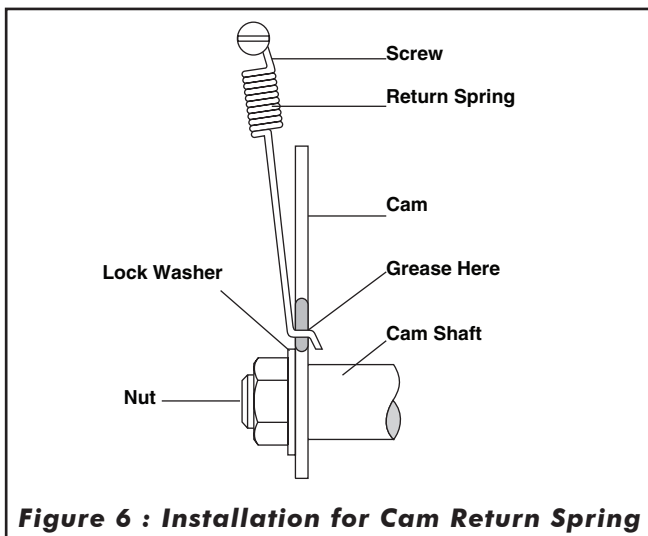

Figure 6 : Installation for Cam Return Spring

Removal and Repair of Instrument

Repairing Capsule Assembly

Refer to the appropriate figure, 2 or 5, and proceed as given below:

NOTE : In case the instrument capsule assembly is damaged, the complete instrument capsule assembly along with the balance beam is available. It can be replaced as a whole unit. Also, it can be disassembled and only the faulty soft goods can be changed.

1. In case the entire instrument capsule assembly is to be replaced, the pilot valve should be first removed. (Refer steps 1 and 2 in the preceding section). The two screws fastening it to the base are then to be removed. Ensure that the new instrument capsule O-ring (48) is installed in the instrument capsule assembly at the base. The two mounting screws (35) need to be installed and tighten them. As described in step 7, reinstall the pilot valve.

2. Please follow the guidelines mentioned below in case of disassembling the instrument capsule and replacing the diaphragms: The pilot valve needs to be removed. For this, refer steps 1 and 2 of the preceding section. By removing two screws (35), Separate the instrument capsule assembly from the positioner base. The nut (38) from the top of the balance beam should be removed. The four screws (36, 37) that attach the balance beam to the assembly (41) of the instrument capsule body need to be removed. The balance beam assembly (41) can then be removed.
3. The four screws (39) holding the upper diaphragm retaining plate (42) to the instrument capsule assembly need to be removed. From the assembly, remove the upper diaphragm retaining plate (42) and the lower diaphragm retaining plate (50). Push the diaphragm assembly (49) through the hole and out the bottom of the instrument capsule base - with great care. The instrument diaphragm assembly should be checked for wear and tear and replaced if needed. Remove and save the feedback screw to replace the diaphragm assembly (51) from this assembly.
4. Apply a small amount of thread locking compound (Loctite #222 or equivalent ad-hesive) to the threads. Attach the feedback screw (51) to the new instrument diaphragm assembly. The feedback screw (51) needs to be twisted into the instrument diaphragm assembly until it is flush with the bottom of the diaphragm assembly - approximately. Protruding should not happen.
5. Fold up the corners of the smaller diaphragm on the diaphragm assembly (49) and work it through the hole in the instrument capsule base (43). You need to be careful while doing this. The diaphragm assembly needs to be aligned or rotated so that the small tapped hole in the diaphragm assembly hub is oriented downward closest to the mounting base. While making sure that all the diaphragm corners are lying flat, installation of the lower diaphragm retaining plate (50) and the upper diaphragm retaining plate (42) over the diaphragm should be done. Install and securely tighten the four screws (39). A small amount of Loctite #222 needs to be applied to the shorter threaded portion of the spring and stud assembly (45, 46, 47) and screw it into the diaphragm center hub until the spring coil bottoms out against the center hub. The nut needs to be thread (44) onto the longer portion of the stud assembly until it bottoms out against the top of the coil spring (46).
6. Apply small amount of Loctite #222 or equivalent to each screw. With four screws (36,37), reinstall the balance beam assembly. Use the flat washers under the two widely spaced screws. The thin flexures on the balance beam should not be bended. Thread the bottom nut (44) against the top of the spring coil. Install the top nut (38) and tighten it firmly. This will attach the balance beam to the diaphragm assembly. A new O-ring (48) must be installed in the instrument capsule base. The two mounting screws (35) to be installed and the assembly should be fastened securely to the positioner base (7)
7. For reinstalling the pilot valve, the three pilot valve O-rings (54) should be replaced. Compress the leaf spring on the end of the balance beam and carefully engage the notched end of spool with the beam spring. Spool should slide until it is aligned with its mounting holes. With two screws (53), fasten securely. The range arm need to return to the base and secured with snap ring (8). With one end engaging the feedback screw and the other end engaging the zero screw, reinstall the feedback spring. Calibrate positioner according to "Calibration" section of this manual.

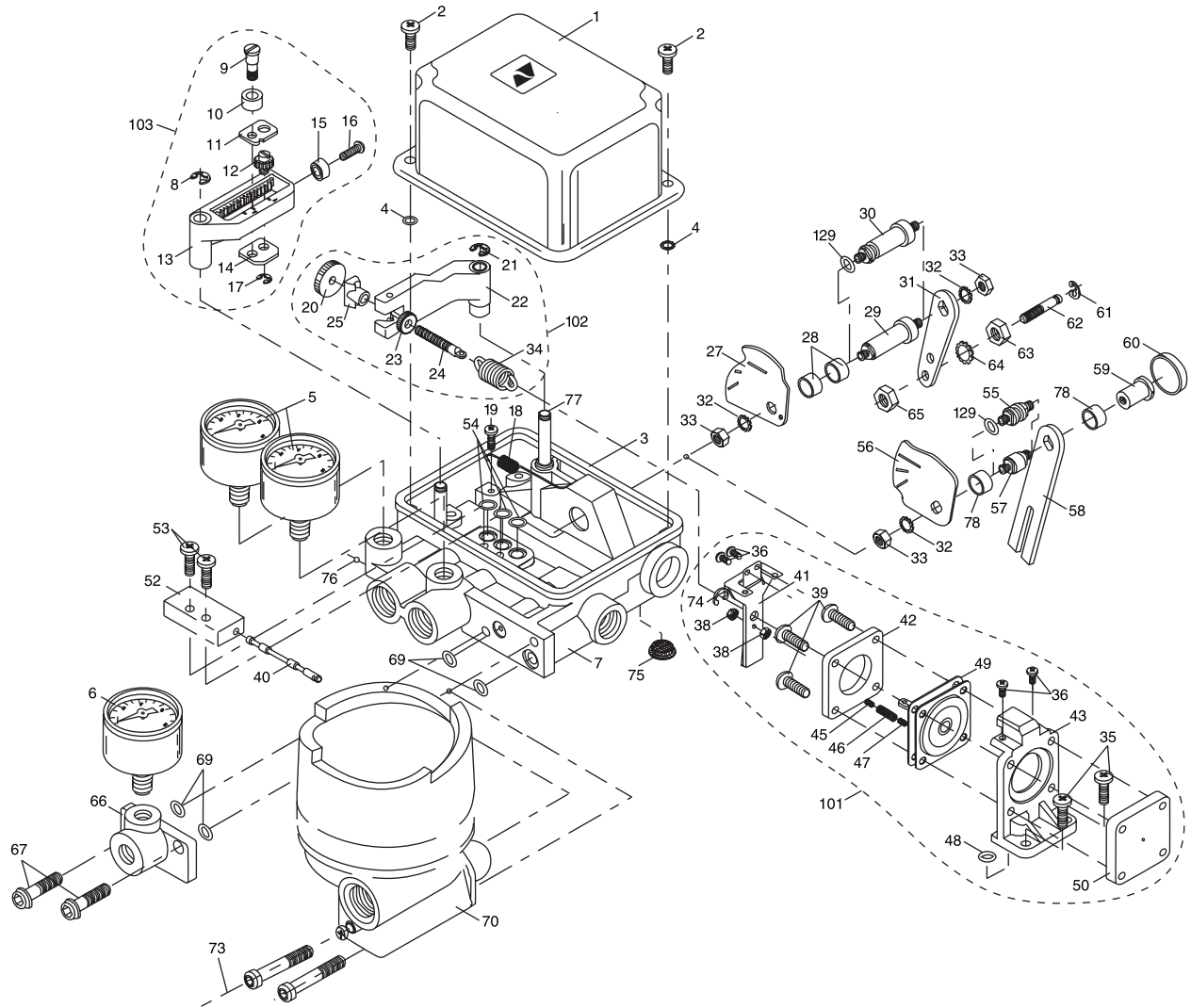

Figure 7 : HiFlo Positioner - Exploded View

Positioner Parts List*

- | | | | |
|-----------------------------|-------------------------------|-------------------------------------|------------------------------------|
| 1. Cover | 20. Zero adjustment knob | 40. Spool | 61. Snap rings |
| 2. Screw | 21. Snap ring | 41. Summing beam assembly | 62. Follower pin |
| 3. Gasket | 22. Zero arm | 42. Upper diaphragm retaining plate | 63. Nut |
| 4. O-ring | 23. Zero adjustment lock knob | 43. Diaphragm base | 64. Lock washer |
| 5. Pressure gauge 0-150 psi | 24. Zero adjusting screw | 45. Stud | 65. Nut |
| 6. Pressure gauge 0-30 psi | 25. Pivot | 46. Spring | 66. Pneumatic adapter |
| 7. Base | 26. Lock washer | 47. Stud | 67. Bolt, socket head |
| 8. Snap ring | 27. Cam, linear | 48. Instrument capsule O-ring | 69. O-ring |
| 9. Pivot screw | 28. Bushing, linear | 49. Instrument diaphragm assembly | 70. I/P module assembly |
| 10. Pivot bushing | 29. Cam shaft, linear | 50. Lower diaphragm retaining plate | 73. Bolt, socket head |
| 11. Front range plate | 30. Cam shaft, linear, vented | 52. Spool valve body | 74. Snap ring |
| 12. Range adjustment gear | 31. Follower arm | 53. Screw | 75. Vent screen |
| 13. Range adjustment arm | 32. Lock washer | 54. Spool valve O-rings | 76. Ball |
| 14. Rear range plate | 33. Nut | 55. Cam shaft, rotary, vented | 77. Post |
| 15. Bearing | 34. Feedback spring | 56. Cam, rotary | 78. Bushing, rotary |
| 16. Screw | 35. Screw | 57. Cam shaft, rotary | 101. Instrument diaphragm assembly |
| 17. Snap ring | 36. Screw | 58. Follower arm, rotary | 102. Zero adjusting arm assembly |
| 18. Return spring | 38. Nut | 59. Cam shaft nut, rotary | 103. Range arm assembly |
| 19. Screw | 39. Screw | 60. Cap, rotary | 129. O-ring, vented |

* All of the above parts are in stock, and can be purchased in any one of 34 spare parts kits. For selecting and ordering the appropriate kit or a new positioner, contact your Mascot representative or the factory.

HiFlo Positioner Troubleshooting

Failure	Probable Cause	Corrective Action
Valve won't stroke, no excessive air is exhausting from positioner	1 Tubing to wrong ports 2 Cam action reversed 3 Lever arm stuck 4 Pilot spool stuck 5 I/P converter filter plugged 6 I/P converter failure 7 I/P mounting bolts loose	1 Retube to correct ports (see "Installation" section) 2 Refer to installation section and reverse cam 3 Work with stuck arm until it freely turns 4 Work spool by hand until it freely moves, or remove spool and spool valve body and clean thoroughly; replace if necessary 5 Remove I/P converter and replace filter 6 Replace I/P converter 7 Tighten mounting bolts
Actuator goes to full signal position, regardless of signal	1 Broken feedback spring 2 Linkage is disconnected, stuck or missing parts 3 Pilot spool stuck 4 I/P converter orifice plugged	1 Replace feedback spring 2 Check and tighten all bolts and nuts in linkage, make sure linkage doesn't stick. 3 Work spool by hand until it freely moves, or remove spool and spool valve body and clean thoroughly; replace if necessary. Do not apply grease to spool valve. 4 Return I/P converter to factory for service
Calibration shifts	1 Loose positioner mounting 2 Loose linkage 3 Loose zero adjustment locking knob 4 Worn arms or pins 5 I/P mounting loose	1 Remove cover and check three screws holding positioner to bracket, check two bolts holding bracket to yoke 2 Tighten all nuts and bolts on linkage 3 Tighten zero adjustment locking knob or range adjustment locking knob adjustment after calibrating knob 4 Replace arms or pins, and apply grease 5 Tighten mounting bolts
Excessive air consumption (other than normal exhaust)	1 Air leakage from O-rings 2 Air leakage from tubing 3 Leaky cylinder piston O-rings	1 Remove spool valve; Check O-rings and replace if necessary 2 Tighten or replace tubing fittings 3 Replace O-rings in cylinder
Actuator strokes very slowly in one direction only	1 Connection between capsule and beam improperly adjusted spring 2 Tubing to cylinder is restricted 3 I/P converter filter plugged	1 Retighten balance beam to diaphragm assembly with nut bottomed out against coil of (See step 6 in "Removal & repair of Instrument Capsule Assembly") 2 Locate faulty tube and replace it 3 Remove I/P converter and replace filter
Erratic operation	1 Dirt build-up inside spool valve 2 Bent spool 3 Broken linkage or positioner parts	1 Disassemble; clean spool and body; add air filter to air supply; if air filter exists, replace cartridge 2 Replace spool and valve block 3 Replace broken parts



Our reputation

166 / 167, G I D C, Naroda, Ahmedabad : 382330. India
 Phone : +91 79 22821619/22823369, Fax : +91 79 22822430
 Email : info@mascotvalves.com / web : www.mascotvalves.com