

Installation, Operation, Maintenance Instructions

Spring Cylinder Rotary Actuators

CAUTION :

1. Use pressure relief valves for high pressure piping.
2. Use explosion proof valves/accessories for dangerous media piping.
3. Use fire safe valves for piping where chances of fire by external means.
4. Use seismic proof valves where chances of earthquake are frequent.
5. Check whether location of the valve mounting is of the same service/application as specified on the marking plate.

GENERAL INFORMATION

These instructions are designed to assist in installation, troubleshooting, and servicing of Mascot spring cylinder actuators. The manual should be thoroughly reviewed by Product users and maintenance personnel before performing any operation on the actuator. Additional features (such as DiskFlo & VFlo body assembly, hand wheels, limit stops, fail-safe systems, limit switches, etc.) are covered in a separate instructions cover. The appropriate installation operation and maintenance instructions for installing, maintaining, troubleshooting, calibrating, and operating Mascot positioners should be referred to.

Please follow the instructions as presented. This will help prevent any possible mishaps and injuries. Do not modify this product or substitute nonfactory parts. Do not use maintenance procedures other than the prescribed ones, otherwise the performance will be adversely affected and also will be hazardous to personnel and equipment. This will also cause the existing warranties to be null and void.

WARNING : When working on this, or any process control product, the standard industry safety practices must be followed. Personal protective and lifting devices must be used as warranted.

Unpacking

During the unpacking of the actuator, the packing list should be checked against the receipt of materials. Detailed list describing the actuator and the accessories are provided in each shipping container.

1. For the actuator to be lifted from the shipping container, the lifting straps are to be positioned and hoisted to avoid damage to the tubing and mounted accessories. Use the lifting ring for lifting - whenever provided. Please do not attach a lifting ring on larger actuators size 200. It is better to use lifting straps through the yoke legs.

WARNING : During lifting of an actuator with lifting straps through the yoke legs, one must have in mind that the center of gravity may be above the lifting point and support must be given to prevent the actuator from rotating. Serious injury to personnel or damage to nearby equipment can take place if proper attention is not paid to this factor.

2. On observation of damage during transit, shipper should be contacted immediately.
3. The Mascot representative is always at your service whenever needed.

Installation

Before installation, ensure that there is adequate overhead space for the actuator to permit comfortable removal from the valve body and for proper maintenance when needed.

Table 1 is provided for reference:

NOTE : In case actuator being attached to a valve body assembly, Maintenance Instructions 1 for overhead clearances should be referred to.

Table 1: Overhead Clearance for Disassembly

Actuator Size	Minimum Clearance
25	6 inches
50	8 inches
100 & 200	9 inches

NOTE : Mascot rotary spring cylinder actuators can be mounted in any position. The most preferred mounting position is the vertical position.

1. The actuator is to be mounted on the desired valve or other mechanical device.
2. Connections for the air supply and instrument signal air lines are marked on the positioner. Connect the air lines accordingly. The cylinder and positioner are suitable for 150 psi air supply. The air regulator is not needed till the supply exceeds 150 psi.

NOTE : There are certain cases where air supply needs to be limited to less than 150 psi. For such cases, a sticker is pasted near the upper air port on the cylinder which will indicate the same.

WARNING : If supply pressure exceeds the recommended limit, injury to personnel or damage to equipment can result.

CAUTION : The transfer case cover plate and yoke must be mounted on the actuator prior to it being stroked, otherwise damage will result.

3. It is recommended to install an air filter on the supply line.
4. Use a soap solution to ensure all air connections are free of leaks.

PREVENTIVE MAINTENANCE

Check for proper operation by following the preventive maintenance steps outlined below. These steps can be performed while the actuator is in service and, in some cases, without interrupting service.

Maintenance should be carried out at least once every six months.

WARNING : Keep body parts and clothing, etc. away from all moving parts while the actuator is being operated or serious injury can be caused.

Refer to the "Disassembly and Reassembly" section if an internal problem is suspected with the actuator

1. Damage caused by corrosive fumes and process splatter needs to be examined.
2. Actuator should be cleaned and repainting is to be done in areas affected by severe oxidation.
3. Stroke actuator and check for smooth, full-stroke operation - if possible.
4. Make sure the positioner linkage and splined lever arm are securely fastened. The transfer case cover plate needs to be removed.

CAUTION : Without the cover plate installed, the air must not be applied to the actuator. Or else the unsupported shaft will get damaged. With the valve in service, the cover plate should not be removed.

5. Ensure secure fastening of all accessories, brackets and bolting.
6. When possible, for checking correct fail-safe action, remove air supply and observe the position indicator plate.
7. To check for air leaks through the O-rings, spray a soap solution around the cylinder retaining ring and the adjusting screw.
8. Dirt or other foreign material needs to be cleaned from the shaft.
9. In case an air filter is present, the cartridge should be examined and if necessary, replacement to be done.

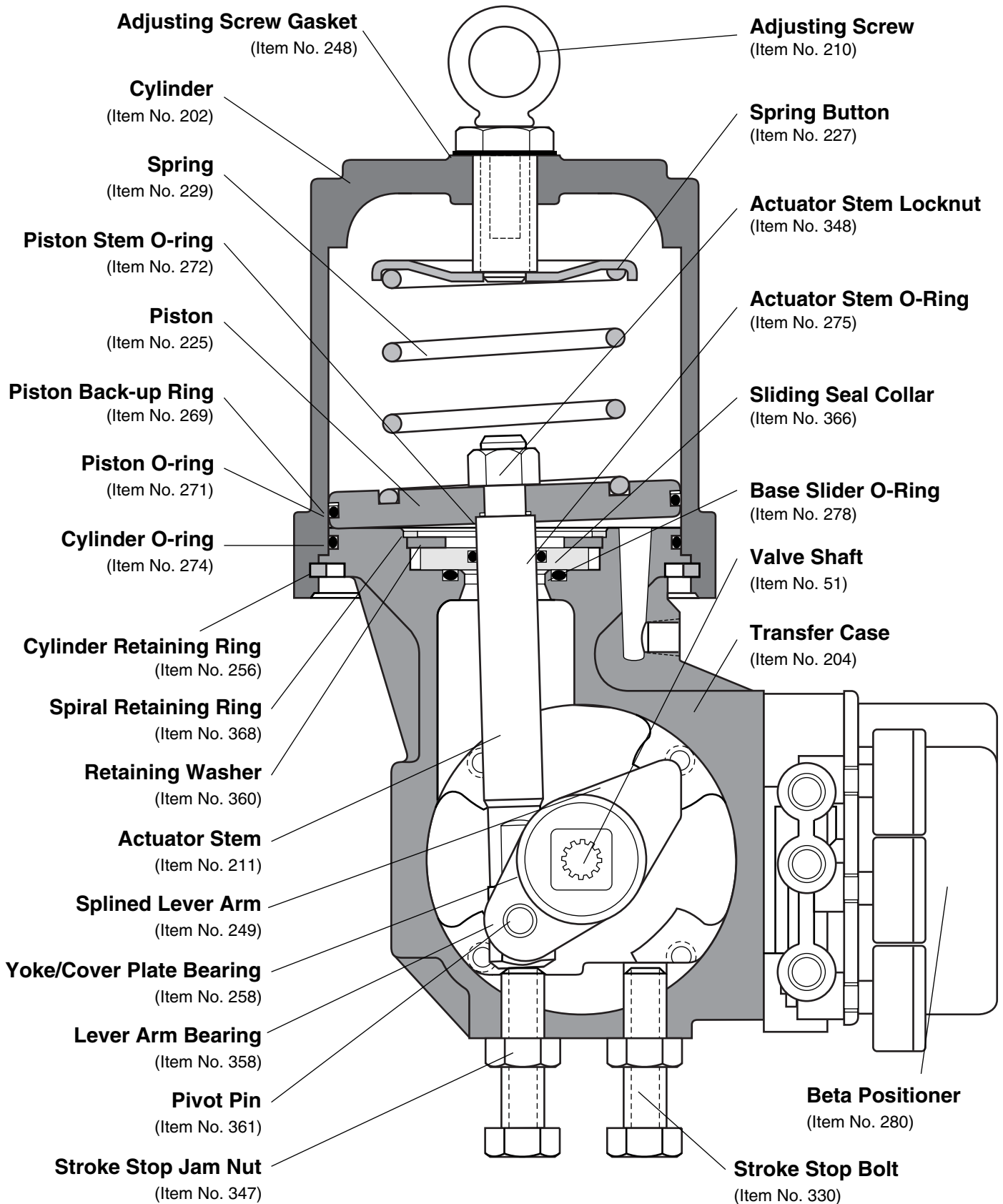

Figure 1 : Sectional View of Rotary Actuator

Note : Item numbers correspond to bill of material of Actuator. Please refer to it for specific part numbers.

Method for removal of rotary actuators from Mascot Valve bodies

When removing a rotary actuator from a Mascot DiskFlo or VFlo valve body, refer to Maintenance In-structions 10 or 9, respectively. When removing a rotary actuator from other manufacturers' valve bodies or equipment, refer to the appropriate literature.

ACTUATOR DISASSEMBLY

If it is necessary to disassemble an actuator refer to Figures 1 and 2, and proceed as follows:

1. Actuator needs to be depressurized and all tubing to be disconnected.

2. The spring compression to be relieved by removal of the adjusting screw.

WARNING : As Spring is under compression, serious personal injury can occur if spring compression is not relieved by removing adjusting screw.

3. Remove the retaining ring from the groove at the base of the cylinder with the help of a screwdriver.

4. The cylinder needs to be pulled off the transfer case and piston.

NOTE : Resistance of O-ring may be felt strongly. **WARNING:** Air pressure must not be used for removal of the cylinder because there is a risk of personal injury.

5. Spring button and spring should be removed.

CAUTION : When removing the actuator stem, one should be careful not to damage the sliding seal assembly or actuator stem O-ring.

6. The actuator stem locknut is to be removed. From the actuator stem, the piston and piston stem O-ring may now be removed.

7. The spiral snap-ring to be removed, holding the sliding seal assembly in place.

8. The retaining washer and sliding seal collar must be removed. It is easy as these components can be usually removed by gently prying the outside surface of the collar upward or with hand.

WARNING : Scratching can cause excessive wear and possible leakage. Avoid scratching the bottom surface of the sliding seal collar with a screwdriver or any sharp object.

9. Remove the four bolts for removing the transfer case cover plate.

10. By removing the four lug bolts, remove the yoke from the transfer case.

11. Remove a retaining ring to remove the pivot pin from the non-clamping lever arm.

12. The actuator stem is now easily removable.

13. First remove the positioner according to the proper positioner maintenance manual The lever arm can be removed now.

14. For replacing the yoke/cover plate bearings, press them out of the yoke and/or cover plate. A press and arbor can be used for this purpose.

15. Replace the non-clamping lever arm bearings by pressing them out. This can be done with a press and arbor.

ACTUATOR REASSEMBLY

Refer to Figures 1 and 2 to reassemble an actuator. Proceed as mentioned below :

1. All internal parts must be cleaned and lubricated. A silicone lubricant (Dow Corning 55M or equivalent) must be used for replacing and lubricating O- rings. Ensure that the bore that houses the sliding seal assembly in the transfer case is smooth and clean.

2. In case the lever arm bearings were removed, new bearings must be installed. A press and arbor can be used for pressing them into place.

3. Through cover plate/yoke openings, install non-clamping lever arm into transfer case.

4. Through the top opening of transfer case, slide the actuator stem. Connect to the lever arm with the two retaining rings and pivot pin.

5. In case the yoke/cover plate bearings were removed, new bearings must be installed. A press and arbor can be used for pressing them into place.

6. Cover plate and yoke to be installed onto transfer case. With the yoke, the four tapered lug bolts are used and with the cover plate, the standard hex bolts are used.

7. The base slider O-ring to be installed into sliding seal groove. The sliding seal groove is machined in the transfer case.

8. Actuator stem O-ring needs to be installed into the sliding seal collar. Then the collar is to slide over the actuator stem.

9. Install the spiral retaining ring into the transfer case while placing retaining washer over the collar and.

10. Making sure that the piston backup ring is on top (toward the top of cylinder) of the piston O-ring, the piston O-ring and piston backup ring need to be replaced onto piston.

Note : Two piston backup rings are used in 200 square-inch actuators. Two piston backup rings are placed on each side of the piston O-ring.

11. The piston stem O-ring and piston need to be installed on to the actuator stem.

12. On the actuator stem, install the spring guide (50, 100, and 200 square-inch actuators only) and actuator stem locknut. Firm tightening of the actuator stem locknut is to be ensured.

13. Into transfer case groove, install the cylinder O-ring.
NOTE : In an event of any damage, replace cylinder O-ring.

14. The spring and spring button should be installed.

15. Over the piston and transfer case, slide the cylinder down.
CAUTION : When sliding it over the piston O-ring, position of the cylinder must be perpendicular with the piston. If not done as prescribed, the O-ring will get damaged.

16. By feeding it a little at a time into the groove, reinsert the cylinder retaining ring in the cylinder. Secure fastening is to be ensured.

WARNING : Serious personal injury is likely if cylinder retaining ring is not completely seated in the cylinder groove.

17. Ensure that the hole in the spring button is centered directly under the adjusting screw hole in the cylinder. The adjusting screw must be installed and tightened just sufficiently to provide an air seal with the gasket. Overtightening to be avoided.

18. Mount positioner and connect tubing in case of actuator is to be used with a positioner.

CAUTION : Prior to stroking the actuator, the actuator cover plate and yoke must be installed or damage is likely.

Adjusting External Stroke Stops

To avoid valve leakage after disassembly and reassembly it is necessary to readjust the external stroke stops. Do the adjustment of the external stroke stops when the valve is out of line. For adjustment of the external stroke stops, the procedure is mentioned below :

CAUTION : a). Actuators must be attached to a valve or other mechanical device b). The transfer cover plate must be installed prior to stroking the actuator. Damage will result in case of noncompliance to the procedure.

1. With very low supply air pressure (10-15 psi), operate the valve (or mechanical device) to just beyond the closed position.
2. As viewed from the end - Turn the stroke stop in clockwise until feeling of resistance. Turn the stroke stop an additional 1/8 turn. See that the valve is closed on dead center. If not, adjustment needs to be done to the stop until the valve is closed on dead center.

Cycle open the valve. Until valve is 90 degrees from the closed position, adjust the other stroke stop.

To make certain the position indicator returns to the same position with each cycle, cycle the valve several times.

4. The stroke stop jam nuts need to be tightened.

REVERSING THE ACTUATOR ACTION

Four different mounting positions, for either fail-close or fail-open air failure operation are allowed for by the rotary actuator transfer case, without retubing or changing the fail-safe spring in the actuator.

Make sure there is no line pressure in the valve and support the actuator assembly by the lifting ring - This needs to be done before reversing the actuator action. Figures 1 and 2 are to be referred and then proceed as mentioned below:

NOTE : Contact factory if a problem occurs while reversing the actuator action because not all positions are available on all actuator sizes.

1. Relieve spring compression after disconnecting the air.
2. The transfer case cover plate bolts are to be removed. Slide cover plate off the end of the splined lever. Do this carefully.
3. The linkage bolt is to be loosened.
4. The bolts connecting the transfer case to the yoke are to be removed.
5. The actuator assembly to be slid off the shaft. In case it is needed, wedge the splined lever arm apart.
6. By manually rotating it 90 degrees, index the valve. In case of a closed valve, rotate to the open position or vice versa.
7. By turning it 180 degrees, reverse the transfer case on the yoke. The yoke side and the cover plate side interchange their positions. It may be necessary to change the mounting position of the valve in line to achieve the proper orientation since this changes the direction of the actuator's rotation.

NOTE : Prior to reconnecting of the actuator to the valve, ensure that the valve rotation matches the actuator rotation and the air failure requirement is complied.

8. The actuator has to be connected to the valve or mechanical device.

Troubleshooting Rotary Actuators

Failure	Probable Cause	Corrective Action
Actuator operates, shaft does not rotate	<ol style="list-style-type: none"> 1. Broken actuator stem 2. Broken pivot pin 3. Sheared connection at splined lever arm 	<ol style="list-style-type: none"> 1. Replace actuator stem 2. Replace pivot pin 3. Replace splined lever arm or valve shaft
Jerky shaft rotation	<ol style="list-style-type: none"> 1. Cylinder wall not lubricated 2. Worn piston O-ring or load bearing ring allowing piston to gall on cylinder wall 3. Worn (or damaged) valve thrust bearings, shaft bearings or packing followers 	<ol style="list-style-type: none"> 1. Lubricate cylinder with silicone lubricant 2. Replace O-ring or load bearing ring; if galling has occurred, replace all damaged parts 3. Disassemble and inspect parts; replace any worn or damaged parts
High air consumption or leakage	<ol style="list-style-type: none"> 1. Leaks in the air supply or instrument signal system 2. Malfunctioning positioner 3. Leaks through O-rings or adjusting screw gasket 4. Worn O-rings in sliding stem seal assembly 	<ol style="list-style-type: none"> 1. Tighten connections and replace any leaking lines 2. Refer to positioner's maintenance instructions 3. Replace O-rings or gasket 4. Replace assembly

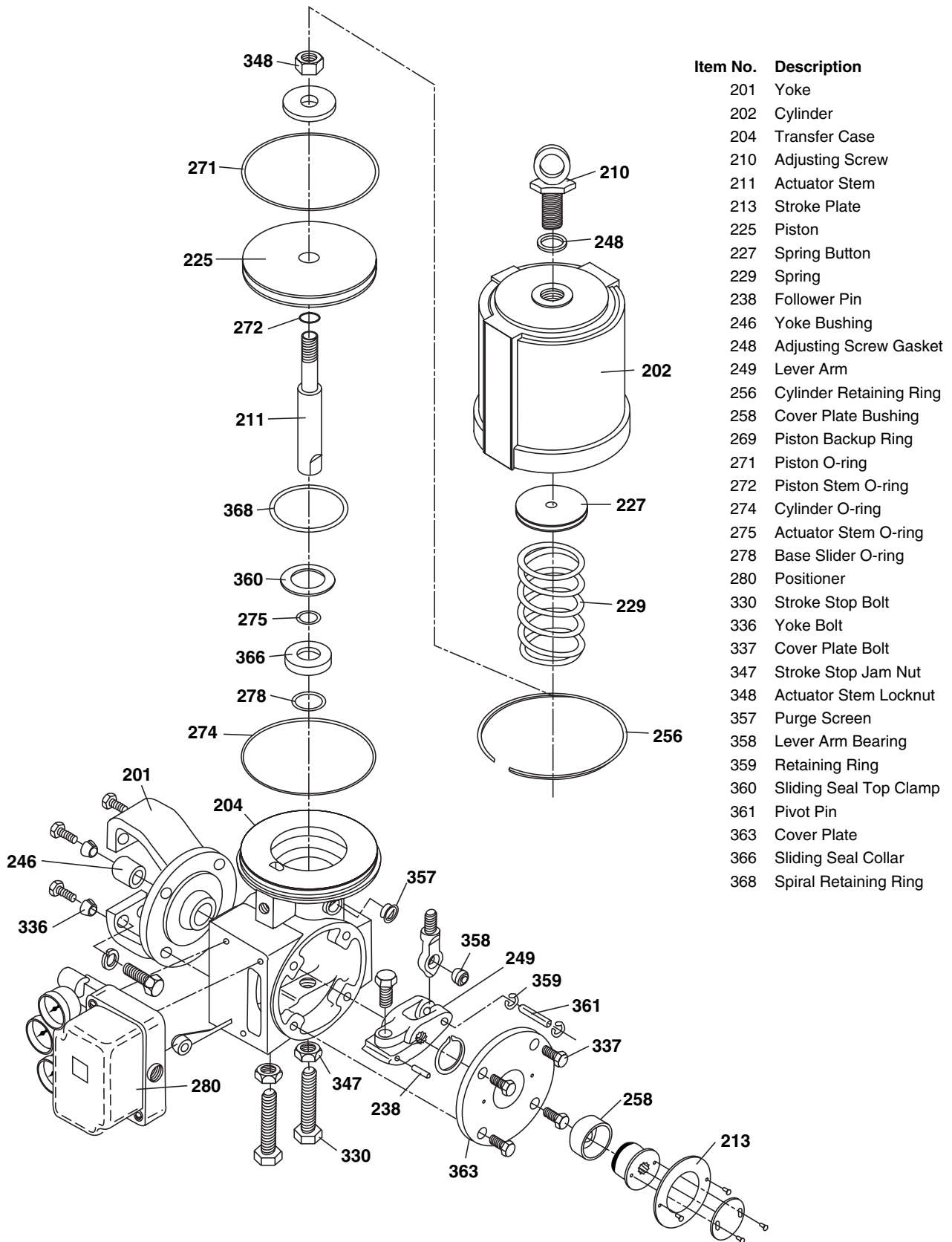
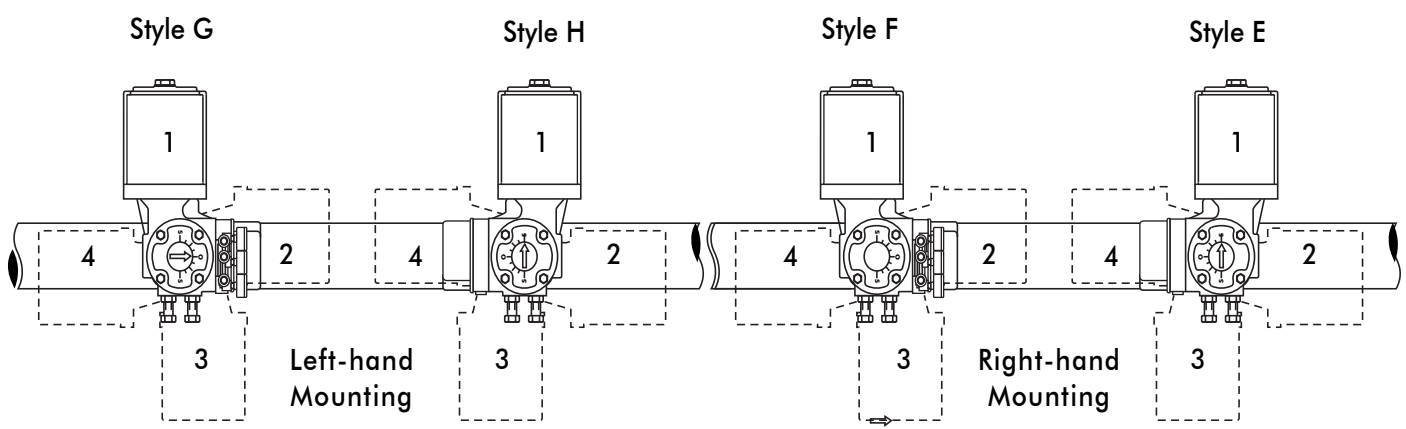
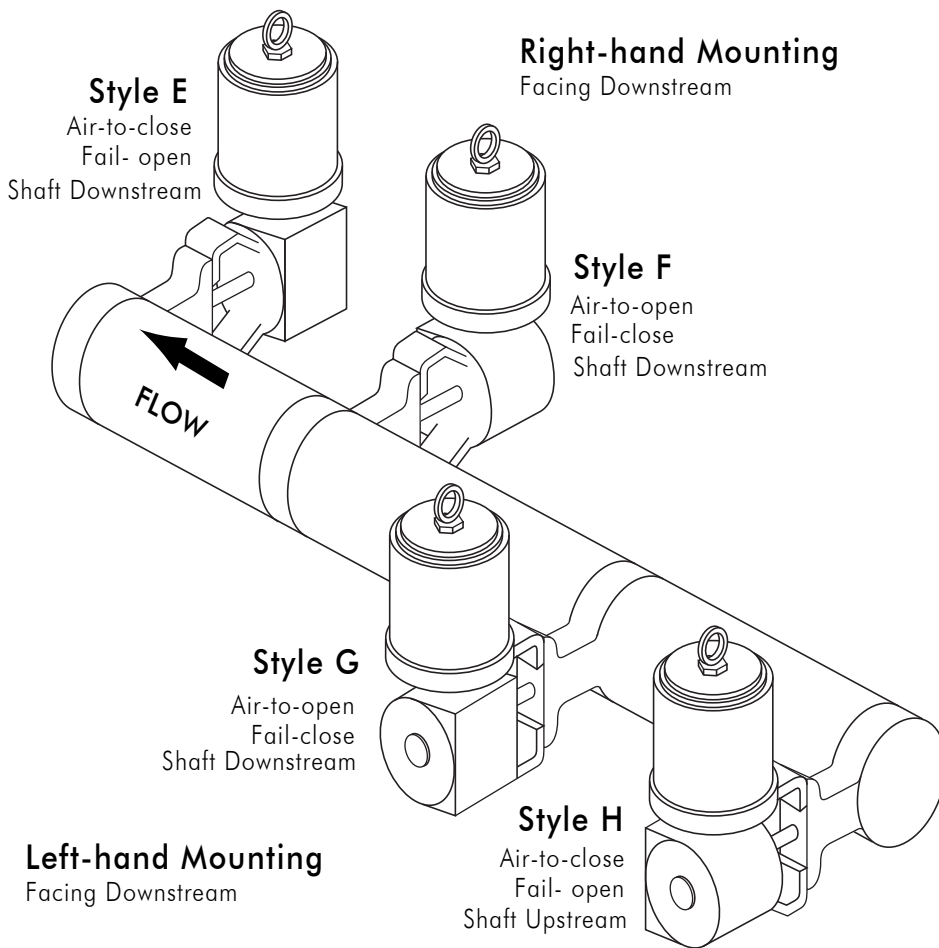

Figure 2: Exploded View of Rotary Actuator

Note : Item numbers correspond to bill of material of Actuator. Please refer to it for specific part numbers.



NOTE: Orientation 1 is standard. Orientation positions 2 and 4 are not available in some actuator sizes. Contact Us.

Figure 3 : Transfer Case Mounting



Our reputation

166 / 167, G I D C, Naroda, Ahmedabad : 382330. India
Phone : +91 79 22821619/22823369, Fax : +91 79 22822430
Email : info@mascotvalves.com / web : www.mascotvalves.com